

MAINTENANCE
INSTRUCTIONS

COMP
DOOR™

KEEP YOUR COMPDOOR LOOKING GREAT BY
FOLLOWING THESE SIMPLE INSTRUCTIONS

CYLINDER LOCKS

Lubricate 6 monthly using Compdor Cylinder lubrication oil.

1. Apply 4 drops on each side of the key
2. Place the key in the lock & move back & forth 10 – 15 times to lubricate the cylinder
3. Repeat at least once a year, or when necessary

DO NOT USE WD40 or 3-in-1 oil

MULTIPOINT LOCKS

- Wipe the door lock and keeps down with a clean damp cloth to remove dirt/grit
- Do not use household chemical cleaners or abrasive cleaners
- Do not use any cleaners which may affect the corrosion resistance of the product
- Avoid acid or ammonia-based cleaners & wipe dry after cleaning
- Twice per year apply petroleum jelly to all “contact” areas of Lock & Keeps as shown (Grease Points)
- Periodically inspect all fixings are secure. Any loose fixings should be tightened by a suitably qualified person

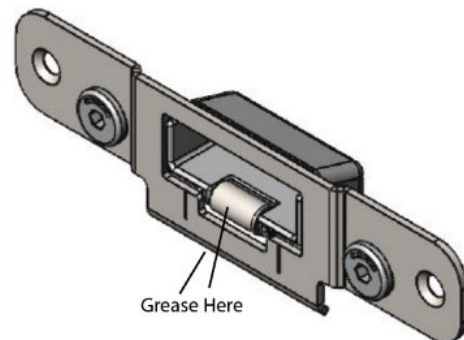
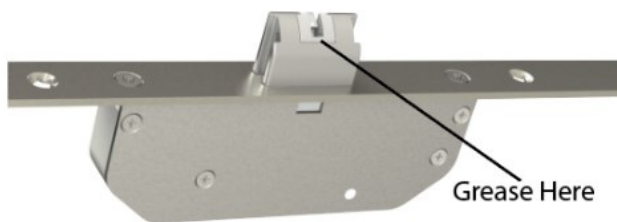

DOOR FURNITURE (NOT STAINLESS STEEL)

For continued protection of the quality finish and appearance of all Fab & Fix hardware (letterplates, Handles, Knockers & Hinges) routine cleaning must be carried out, wash the hardware with a very mild soapy water and a cloth – making sure to dry well afterwards.

Moving parts should also be lightly lubricated using 3 in 1 oil at least twice a year. This procedure is particularly essential if products are installed within a 25-mile radius of coastal areas or close proximity to a building site or large industrial area, where more frequent cleaning may be required to prevent the accumulation of corrosive contaminants.

DOOR FACES & FRAME

Using only soapy water and a sponge, wipe down the faces of the door and frame and immediately dry them using a towel, this should be repeated every month.

316 STAINLESS STEEL HARDWARE

To help you care for the BLUTM product range please follow the guidelines below.

During installation and if building work is being carried out the hardware should be covered to protect it from dust, dirt and scratching. Immediately after fitting and installation Product should be cleaned using a soft cloth and mild soapy water then dried immediately with a clean, soft cloth.

MONTHLY CARE AND MAINTENANCE

Clean regularly with a soft, dry cloth or duster. Rubbing or wiping should be carried out in the direction of the polish/finishing lines, not across them.

Product should be washed monthly using a soft cloth and mild soapy water then dried immediately with a clean, soft cloth - especially if fitted on or near the coast, fingerprints can be removed by washing product as above.

SIX MONTHLY CARE AND MAINTENANCE

Stainless steel finish should be cleaned using the Compdoor Stainless Steel Renovation Kit at least every six months to help maintain this product stay in pristine condition. Lubricate any moving parts with a suitable PTFE Grease. Compdoor Stainless Steel Renovation Kits are available from our website.

Please Note

- DO NOT use oily rags or greasy cloths when wiping the product surface
- DO NOT use bleach, abrasive cleaners, caustic or acid-based cleaning materials or detergents containing chloride, or any strong household cleaning products
- DO NOT use abrasive materials, files or other hard objects against the product surface
- This product should be protected from dust and dirt during any construction work
- If a softer metal such as a ring or a key marks the surface, it is possible some of the metal may have been left on the surface. In this case use a soft cloth and mild, non-acidic cleaner to remove the soft metal deposit



Have a question? Get in touch:

Tel: 01782 340 444

Email: info@compdoor.co.uk

www.compdoor.co.uk

COMP
DOOR[™]